

ALCO

Forming machine

PRO Series



Improved filling principle for more precise forming and unlimited flexibility in the shaping of your products



alco Forming machine PRO Series



Individually designable and weight-accurate moulds offer you complete creative freedom on an industrial scale

The forming machine is usually combined with other alco equipment, in particular with the double-shaft paddle mixer and the coating technology to achieve a smooth workflow for in line processing.

Benefits

- Excellent results on a wide range of products at maximum yield
- Improved filling principle with up to 70 strokes per minute for even more precise production
- Fully controlled and efficient production times
- Suitable for formed masses of various viscosity, from pasty to coarse
- Quickly changeable moulds in 2, 2.5 or 3 dimensions

Standard version serves best for every smaller production capacity

- Cost-saving alternative to the PRO Series
- Comes with 400 & 600 mm net belt widths
- Up to 55 strokes per minute (product-specific)
- Mould plates can be used both, with the PRO and standard version for maximum flexibility
- Proven and robust construction as well as technology



Visit JBT's fully equipped Food Technology Centres in either Helsingborg, Sweden, Livingston, UK or Bad Iburg, Germany and test the alco forming equipment using your own products and recipes.



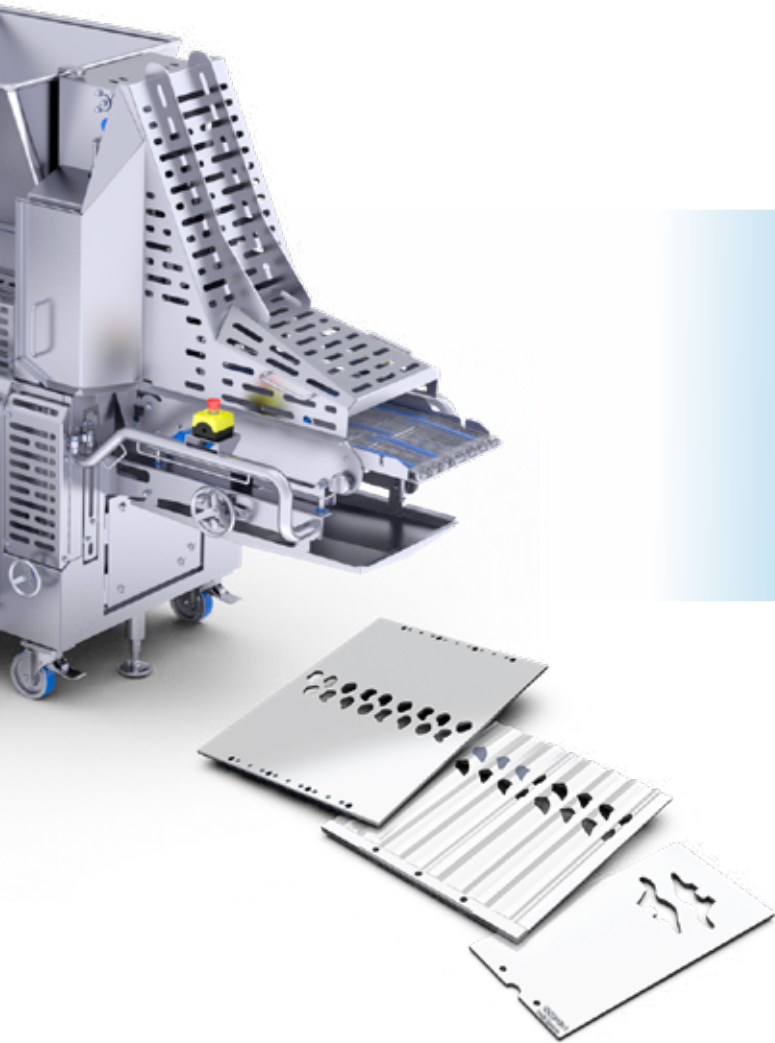

High hygiene standards

- Designed according to latest hygiene and safety standards for top product safety
- Easy operation and thorough cleaning with maximum safety and efficiency
- Optimized maintenance hatches, sealing systems and relocation of individual components
- Minimized residual quantities in the hopper and screw thanks to optimum product material feeding to the moulding plate

State of the art controls

- The forming machine PRO Series comes with a Siemens PLC control panel as standard with an intuitive graphical interface
- Program control system allows a precise control of several parameters, such as production speed
- As every PRO Series machine of alco comes with a PLC touch panel, users can easily navigate through menus on any alco machine in the production line

Wide range of additional equipment

- Design your own forming, filling and venting plates
- New outfeed conveyor with its own drive system offers a higher level of adjustment options and simpler calibration as well as cleaning
- Various configuration options such as a ball rolling unit, cleaning cart, bridge breaker for very tough masses, etc.

Flexible solutions for food processing requirements and applications

All alco machines evolve with the demands of the industry where innovation, versatility and reliability are key. Flexible solutions can be developed for all food processing operations, large or small, and each alco forming machine can be configured to meet individual requirements and a wide range of applications including:

- burgers
- meatballs
- formed schnitzel
- nuggets
- fish sticks
- mozzarella sticks
- plant-based foods

The JBT ALCO Forming machine AFM PRO - Brings your product into shape

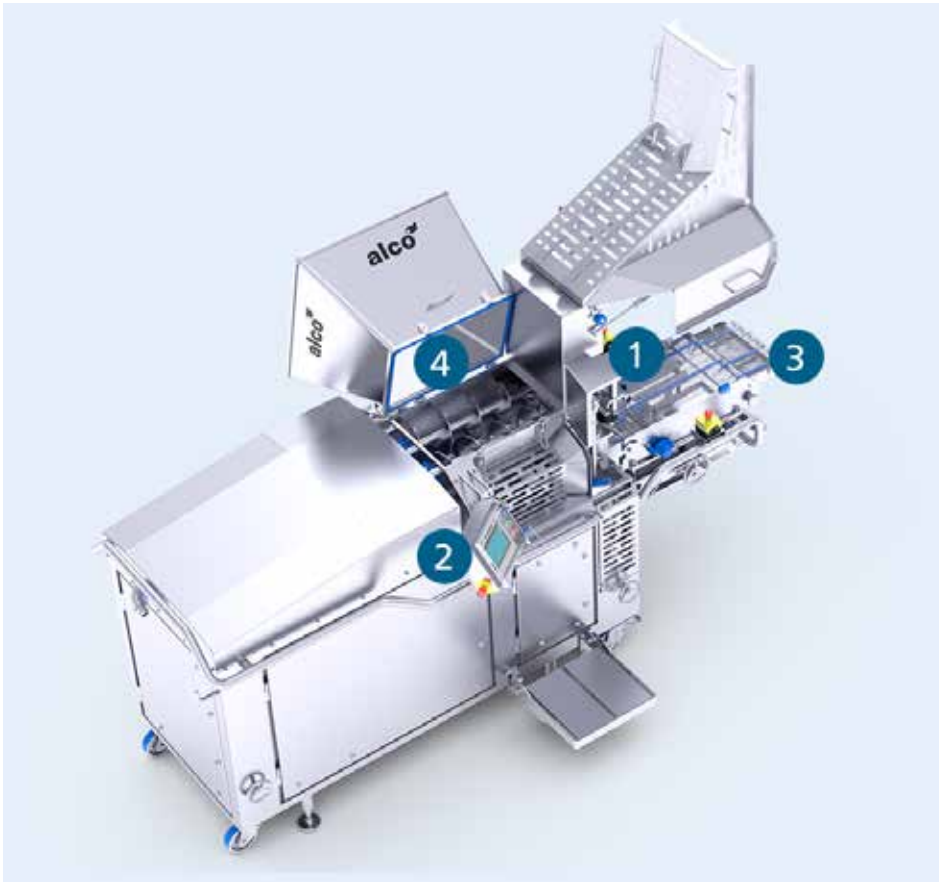

1 High-performance filling system

develops a press force of 80 bar, thus enabling to process the raw mixture at high speed. An optional air ejector allows further production options.

2 PLC Control

controls the system in a smart and user-friendly way through a touch panel with functions like recipe management, etc.

3 Improved outfeed conveyor

with its own drive system offers a higher level of adjustment options and thus simpler calibration and cleaning.

Optional

4 Bridge crusher incl reinforced hopper attachment

Crusher shaft with pneumatic drive system ensures continuous feed to the screws even with stiffer mixtures.

Cleaning cart

allows all loose attachments of the machine to be stored, fixed and given a simple cleaning.

WE ARE YOUR SINGLE SOURCE FOR PROFITABLE PROCESSING SOLUTIONS

JBT is a leading provider of integrated food processing solutions. From single machines to complete processing lines, we enhance value and capture quality, nutrition and taste in food products. With a local presence on six continents, JBT can quickly provide our customers and partners in food processing industry with the know-how, service, and support needed to succeed in today's competitive marketplace.



North America

JBT Corporation
1622 First St.
Sandusky, OH 44870
USA
Phone: +1 419 626 0304
E-mail: process-solutions@jbt.com

Europe

John Bean Technologies AB
Rusthällsgatan 21, Box 913
SE-251 09 Helsingborg
SWEDEN
Phone +46 42 490 4000
info-europe@jbt.com

Asia

John Bean Technologies Ltd.
159/26 Serm-Mit Tower, Room no. 1602-3
Sukhumvit 21 Road, Klongtoey Nua Sub-district
Wattana District, Bangkok 10110, THAILAND
Phone: +66 2257 4000
E-mail: infoasia-jbtfoodtech@jbt.com

Latin America

John Bean Technologies
Máquinas e Equipamentos Industriais Ltda.
Av. Eng. Camilo Dinucci 4605
14808-900 Araraquara, São Paulo, BRAZIL
Phone: +55 16 3301 2000
E-mail: latinamerica.info@jbt.com



We're with you, right down the line.™

jbt.com/foodtech